

DIMENSIONS "TECNIUM" PUMP TYPE:

BTS
5.20



STANDARD	FLANGES	Motor NEMA - IP 55			SPEED RATING/r.p.m.
		Type	KW	Volt.	
	ANSI B16.5 150 Lbs.				3480

SQUARE PLATAFORM

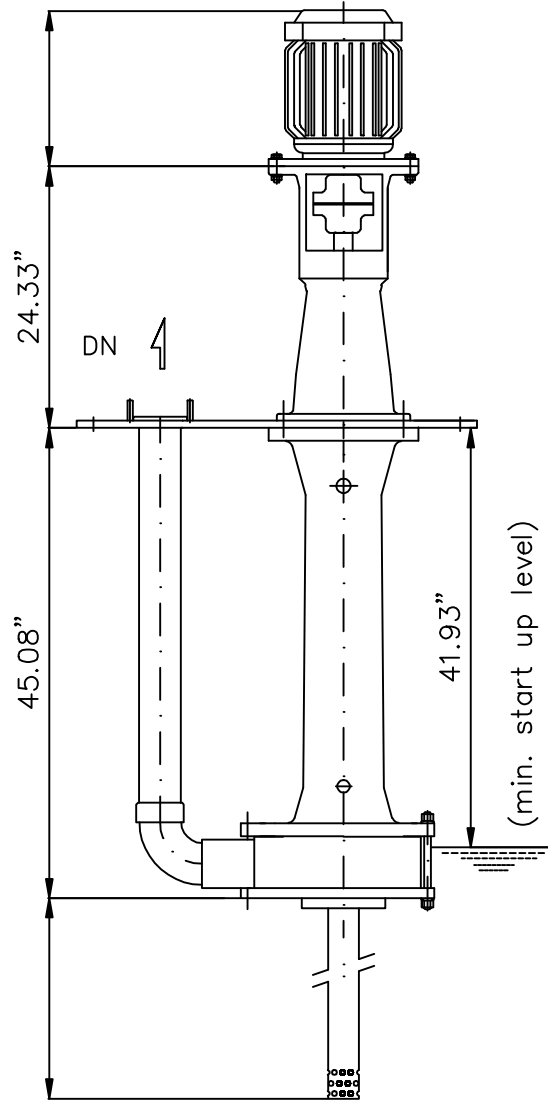
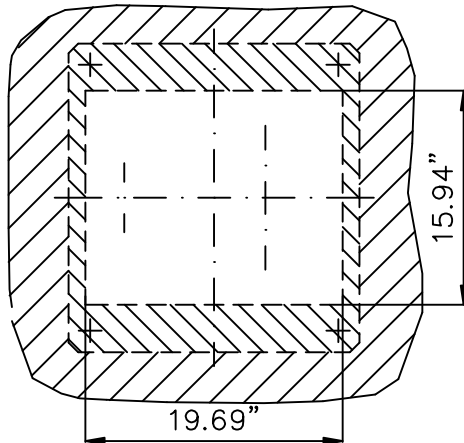
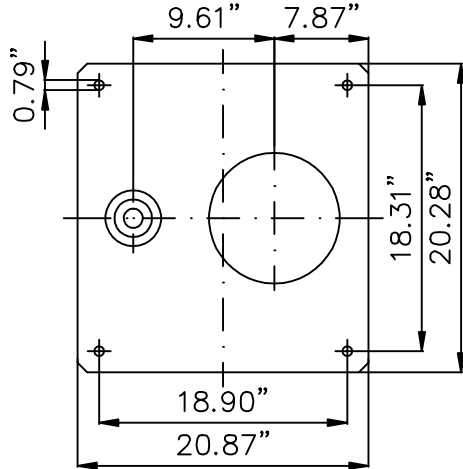

Discharge Df 2"

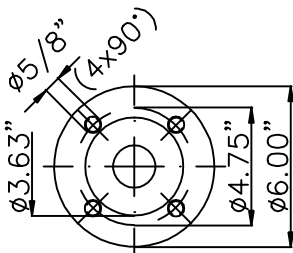

Dimensions in inches

Loads in nozzles

Traction = 292 Lb.

Moment = 11444 Lb.in

Weight (Kg.)

Pump

Motor

ITEM.

ORDER

CUSTOMER

IA. 1.3

Ed. 07.07

TECNIUM®

H.T.

49373