

DIMENSIONS "TECNIUM" PUMP TYPE:

BTS
5.25



STANDARD	FLANGES	Motor NEMA - IP 55			SPEED RATING/r.p.m.
		Type	KW	Volt.	
	ANSI B16.5 150 Lbs.				1750

SQUARE PLATAFORM

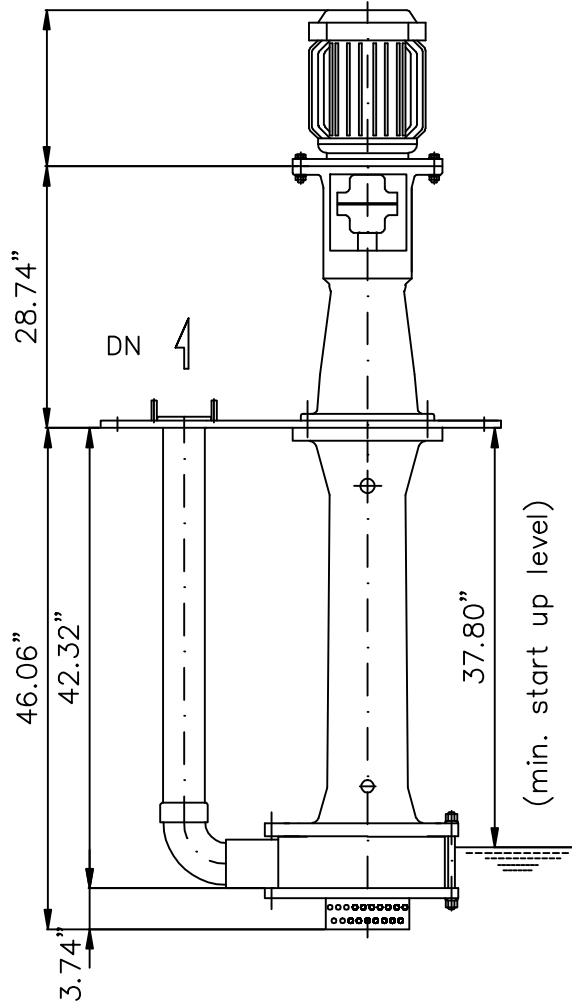
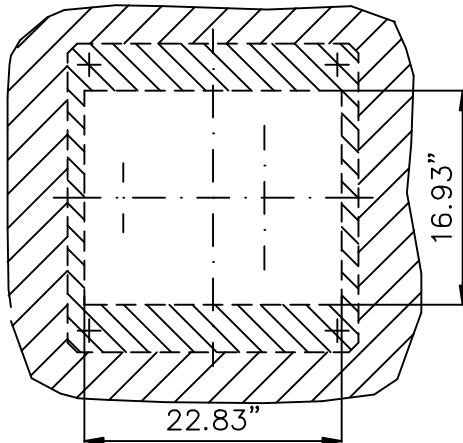
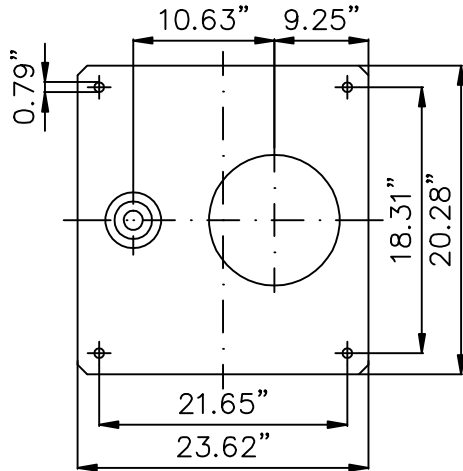

Discharge Df 2"

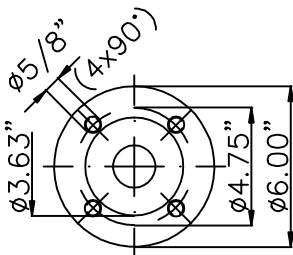

Dimensions in inches

Loads in nozzles
Traction = 292 Lb.

Moment = 11444 Lb.in

Weight (Kg.)	
Pump	Motor

ITEM.
ORDER
CUSTOMER

IA. 1.3

Ed. 07.07

TECNIUM®

H.T.

49374