

DIMENSIONS "TECNIUM" PUMP TYPE:

BTS
5.25



STANDARD	FLANGES	Motor NEMA - IP 55			SPEED RATING/r.p.m.
		Type	KW	Volt.	
	ANSI B16.5 150 Lbs.				1750

SQUARE PLATAFORM

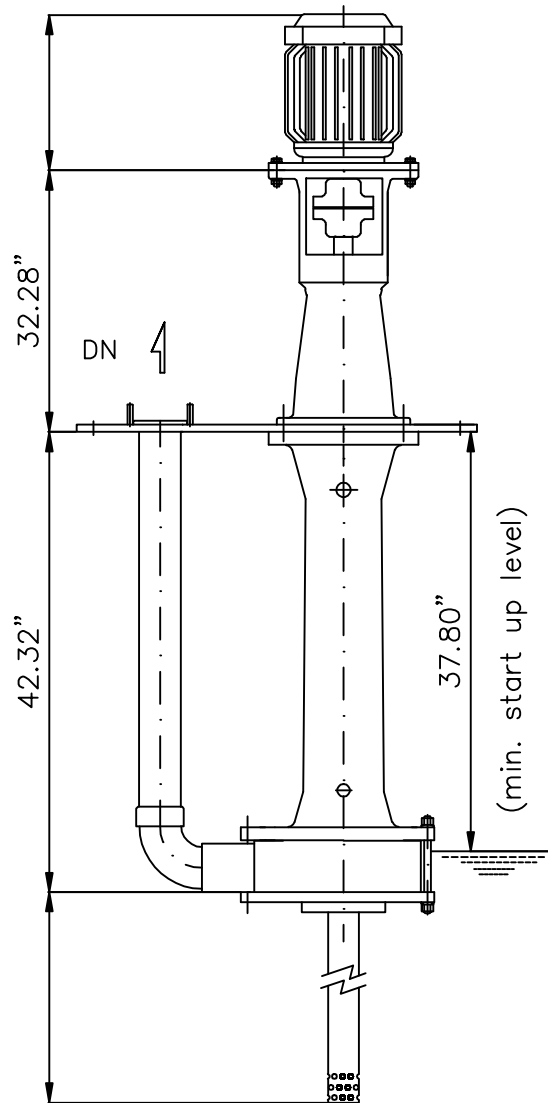
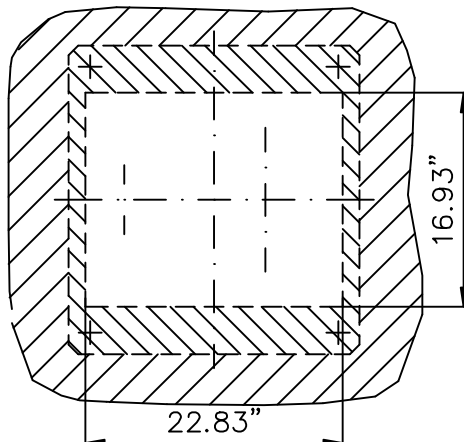
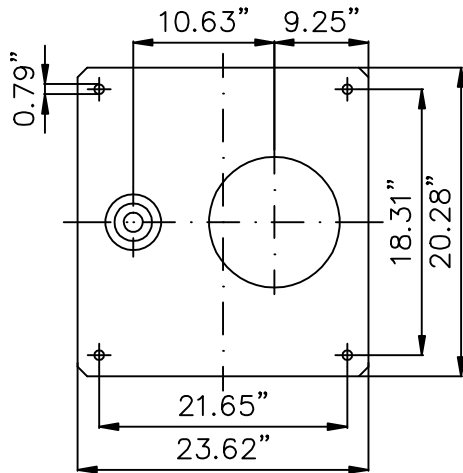

Discharge Df 2"

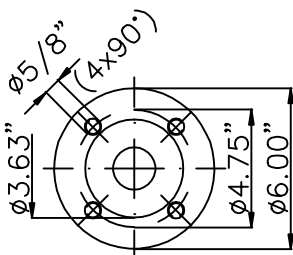

Dimensions in inches

Loads in nozzles Traction = 292 Lb.				Moment = 11444 Lb.in	
Weight (Kg.)				ITEM.	
Pump		Motor		ORDER	
				CUSTOMER	

IA. 1.3

Ed. 07.07

TECNIUM®

H.T.

49375