

DIMENSIONS "TECNIUM" PUMP TYPE:

BNB
80-315

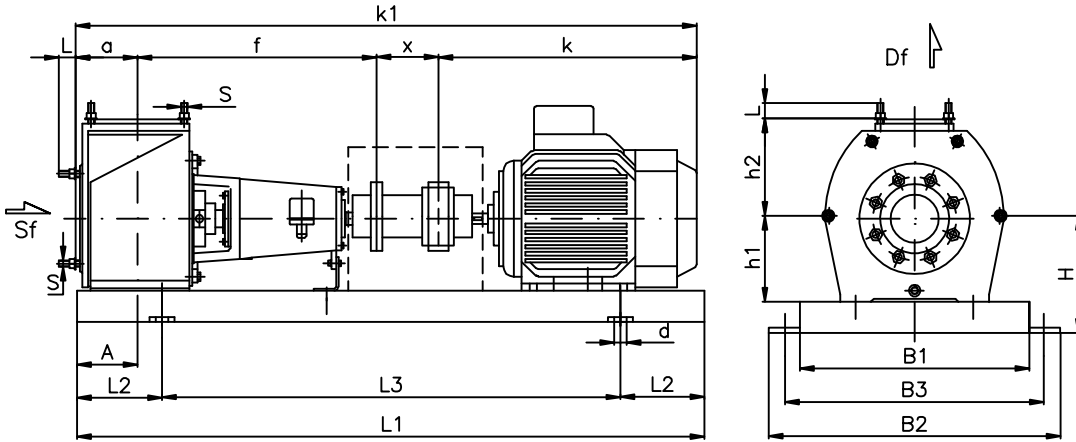

STANDARD	PUMP	BASE PLATE	MOTOR	FLANGES	SPEED RATING/r.p.m.
	DIN EN 22858 ISO 2858 NF E 44121	EN 23661 ISO 3661	NEMA-IP 55	ANSI 150 lbs.	$\frac{1.450}{1.740}$



Pump type	Motor	Pump					Assembly							Base plate				
	Tipo HP	a	f	h1	h2	H	L1	A	B2	k	k1	x	L3	L2	B3	B1	d	
BNB 80-315	20	4.92	20.87	9.84	12.4	15.35	55.1	3.54	24	25.83	57.13	5.51	37	9.06	21.65	18.9	1.06	

	Df	Sf	Discharge Df	Suction Sf	Coupling
DN	3"	5"			} A3 ITEM _____ ORDER N: _____ CLIENT: _____
D	7.5"	10"			
C	6"	8.5"			
U	5"	7.3"			
N°	8	8			
S	5/8"	3/4"			
L	2.52"	2.4"			

Loads in nozzles
 Traction $Df\ 3" = 472\ lb.$
 $Sf\ 5" = 719\ lb.$
 Moment $Df\ 3" = 13645\ lb.in$
 $Sf\ 5" = 16726\ lb.in$

Weight (lbs.)					
Pump	330	Base plate	176	Motor	224.4

Dimensions in inches