

DIMENSIONS MOTORPUMP "TECNUM" BKM 5.9

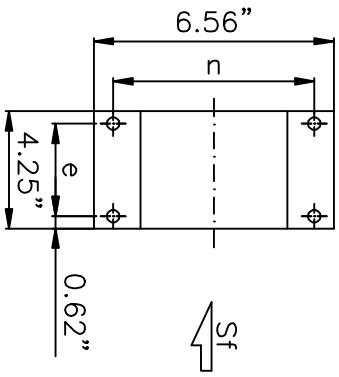

MOTOR	SPEED RATING/r.p.m.	CONSTRUCTION MATERIAL	IMPELLER	ORDER N.:
NEMA-IP 55 C-flange	3480	—	—	—

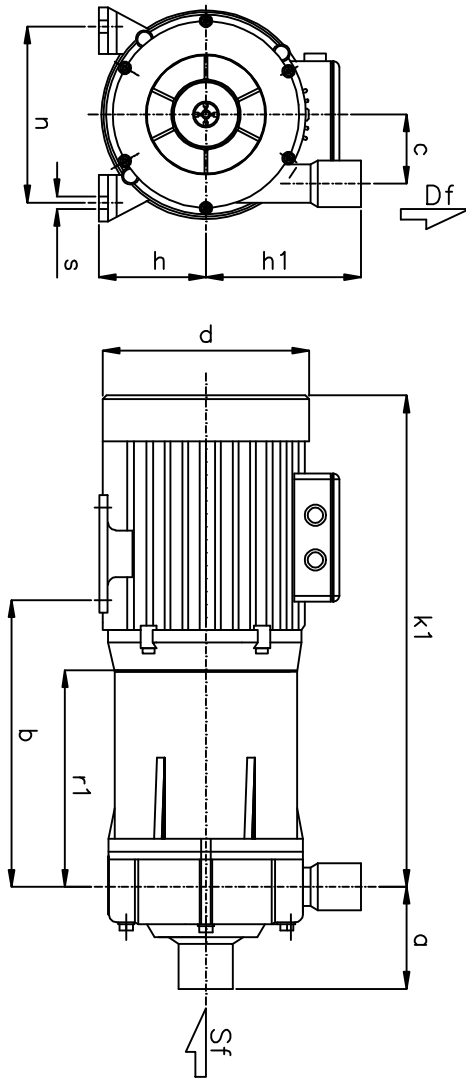

Dimensions in inches.

Pump type	Motor 56	Pump										
	HIP	a	b	c	d	h	h1	k1	r1	n	e	s
BKM 5.9	0.33	2 7/16"	7 7/8"	1 27/32"	5 3/4"	3"	3 15/16"	1 27/32"	5 5/8"	4.88"	3"	1 1/32"

BRIDE OPTIONEL

Discharge Df 3/4"	Suction Sf 3/4"