

DIMENSIONS MOTORPUMP "TECNIUM" BKM 8.11

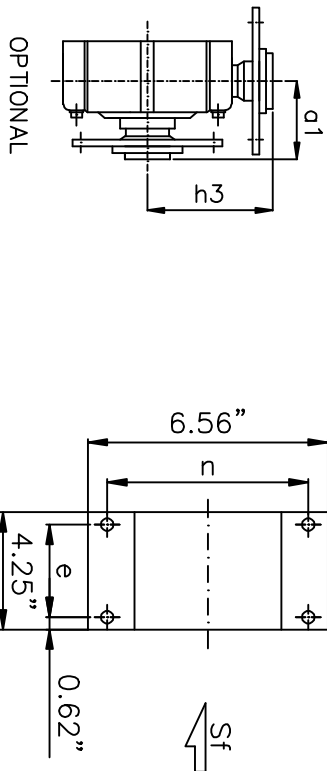

MOTOR	SPEED RATING/r.p.m.	CONSTRUCTION MATERIAL	IMPELLER	ORDER N.:
NEMA-IP 55 C-flange	3480	—	—	_____

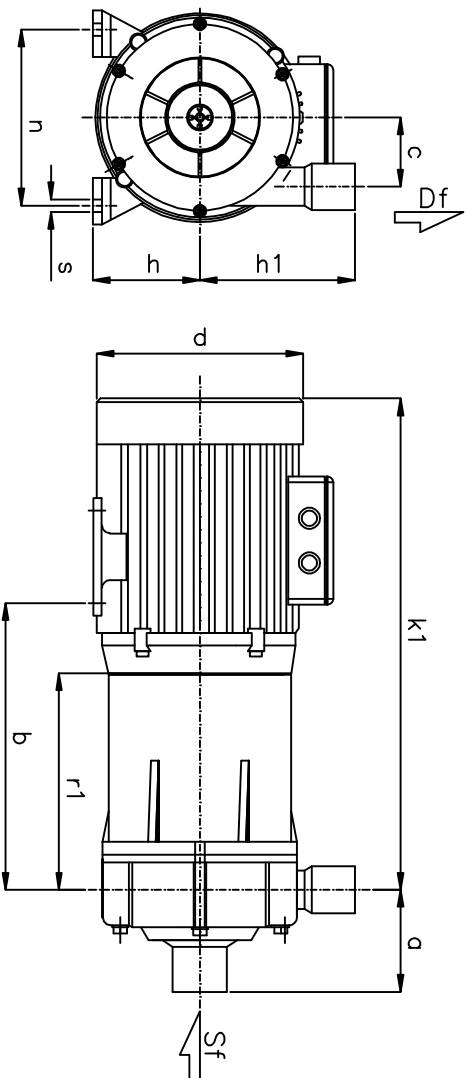

Dimensions in inches.

Pump type	Motor 56	Pump												
		HP	a	a1	b	c	d	h	h1	h3	k1	r1	n	e
BKM 8.11	0.75	27/16"	23/4"	83/16"	23/32"	53/4"	31/2"	315/16"	41/4"	121/4"	55/8"	4.88"	3"	11/32"

BRIDE OPTIONEL

Discharge Df 1 1/4"	Suction Sf 1 1/4"	Discharge Df 1 1/4"	Suction Sf 1 1/4"

Ed. 01/08

TECNIUM®

Tech. Sheet
Ht. 49429