

EDUR[®]

LBU

High-Pressure Multi-Stage Centrifugal Pump

**Shanley Pump
& Equipment, Inc.**





Features

The EDUR LBU High-Pressure Multistage Centrifugal Booster Pump uses a traditional horizontal multistage design of multiple impellers in a segmented pump design on a central shaft to increase flow and pressure.

The design also allows for either single or double acting mechanical seals, gland packing or even magnetic coupling for your Multistage Booster Pump. The flexibility of the design allows for many combinations to achieve the perfect flow and pressure rates for your pumping application.

Description

The EDUR LBU Series High-Pressure Multistage Centrifugal Booster Pump operates at pressures up to 580 PSI with a temperature range of -40°F to +284°F with a Viscosity of 115mm²/s with a maximum series flow-rate of 264 GPM.

The LBU Series offers optional positions of its flanges as well as having the ability act as a liquid-gas pump by being able to transport gases within the liquids without cavitation. For more information about this feature, please contact your Shanley Pump and Equipment, Inc. representative.

The LBU Series is available in Cast Iron, Bronze or Stainless Steel depending upon your application needs.

If you are unsure which EDUR LBU Series High-Pressure Multistage Centrifugal Booster Pump is the right style for you, please ask your Shanley representative for more information to help you make the best selection.



Shanley Pump & Equipment, Inc.
 2525 S. Clearbrook Drive
 Arlington Heights, IL 60005
P: 847.439.9200
F: 847.439.9388
www.shanleypump.com
sales@shanleypump.com

Usage

The LBU Series is a professional's choice for the pumping of clean and slightly polluted liquids. The benefits of the multistage design coupled to the reliability of the EDUR brand allows a wide variety of application industries such as booster systems, irrigation, boiler feed and water treatment and washing plants.

The segmental design of the LBU Multistage Pump comes in a traditional horizontal setup with Vertical options available. The LBU's compact design lets this pump go into many spaces a traditional multistage pump would not fit.

Main Applications

- Irrigation Systems
- Fertilizer Industry
- High-Purity Liquids
- Plant Engineering
- Clear Liquids
- Slightly Polluted Liquids
- Boiler Feed Applications
- High-Pressure Applications
- Liquid-Gas Pumping Applications

GPM Up to 264 GPM

PSI 0 - 580 PSI

TEMP -40°F - 284°F

HEAD 794 ft.

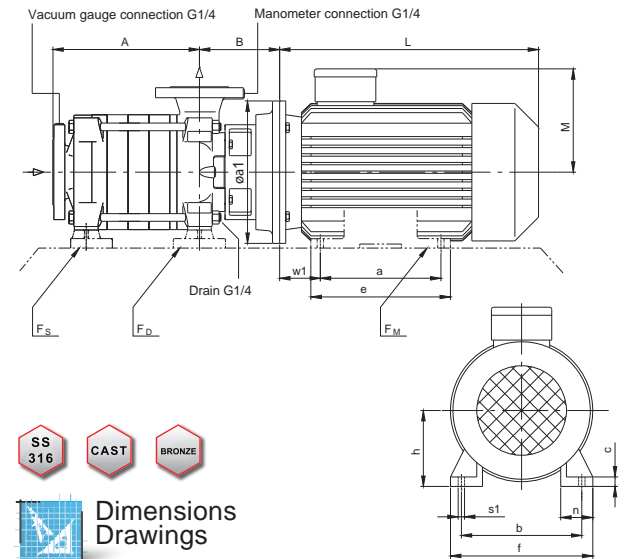

Dimensions Drawings

[Click here for complete dimensional drawings](#)



60Hz
Performance Curve

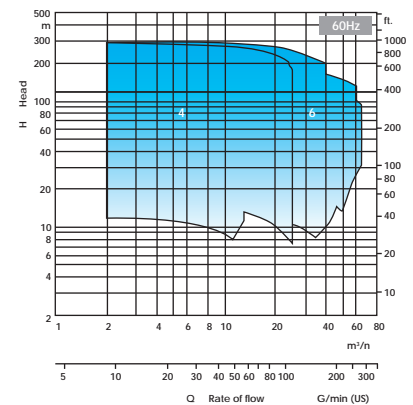

50Hz
Performance Curve

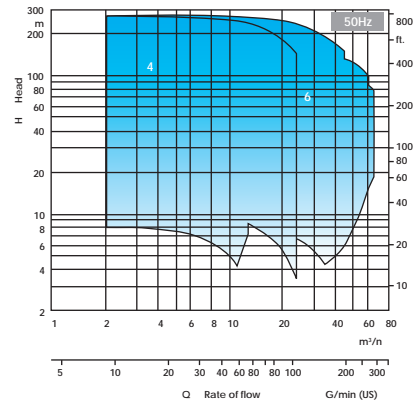

[Click here for complete Flow Curves](#)