

EDUR[®]

NUB

Compact Close Coupled Centrifugal Pumps

**Shanley Pump
& Equipment, Inc.**



NUB EDUR®

Features

The EDUR NUB Series of all-purpose compact single-stage circulation pumps are an ideal addition to your facility for standard pumping applications of clear or slightly polluted liquids.

- Diffuser blades neutralize the radial shaft forces
- Low velocities of flow and low velocity head differences
- Single or double acting mechanical seals
- Capability of transporting gases in the liquid
- Easy maintenance by means of pull-back-design
- Direct installation in stable pipe lines or cantilever mounting
- Any fitting position

Description

The EDUR NUB Series is made from Cast Iron, Bronze or Stainless Steel depending upon your application. The special design of the EDUR NUB Series can also handle small quantities of gases in the pumped liquids without causing cavitation with operating pressures up to 145 PSI at a temperature range of -40°F to +284°F with a Viscosity of 115 mm²/s with a series maximum flow rate of 1,541 GPM.

The NUB Series is also a good candidate for your pumping in the Shipbuilding industry and apparatus engineering requirements with its minimal footprint. The Pump can come complete with either single or double acting Mechanical Seals and is designed as a centrifugal pump with open impellers. Immersible designs of the NUB series are available as well. Balanced Closed Impellers are optional.



Shanley Pump & Equipment, Inc.
 2525 S. Clearbrook Drive
 Arlington Heights, IL 60005
P: 847.439.9200
F: 847.439.9388
www.shanleypump.com
sales@shanleypump.com

Usage

Applications including cooling and Refrigeration technology, air-conditioning, filtration, plastics processing and General machine engineering all are ideal candidates for the EDUR NUB Series Centrifugal Pump.

If you have any questions about the EDUR NUB Series Compact Close Coupled general purpose centrifugal pump please feel free to contact a Shanley Pump representative.

Main Applications

- Cooling Applications
- Air Conditioning
- Filtration Industries
- Plastic Processing
- General Purpose Pumping
- Clear Liquids Pumping
- Slightly Polluted Liquids
- Cooling Systems
- Filtration Systems
- Recirculation Systems

GPM up to 1,541 GPM

PSI 0 - 145 PSI

TEMP -40°F - +284°F

HEAD 180 ft.

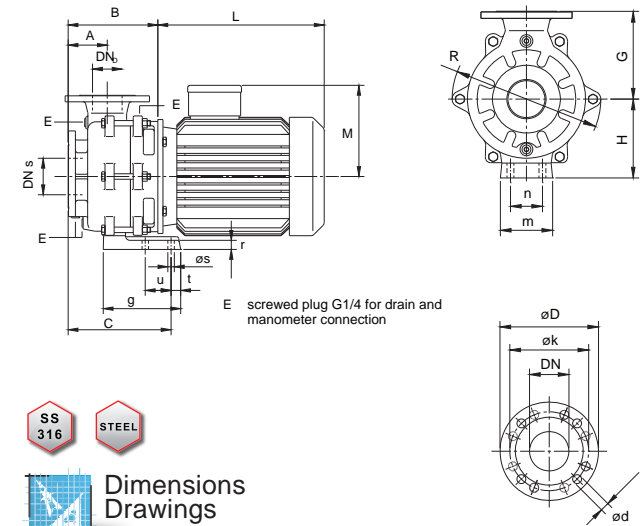

Dimensions Drawings

[Click here for complete dimensional drawings](#)



60Hz Performance Curve

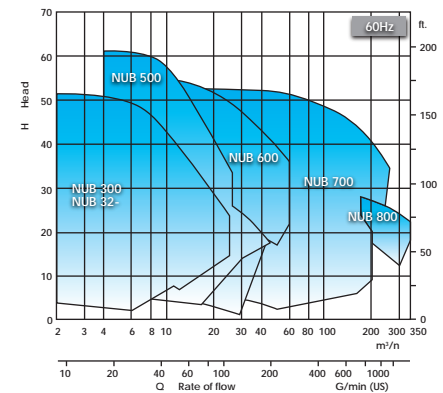

50Hz Performance Curve

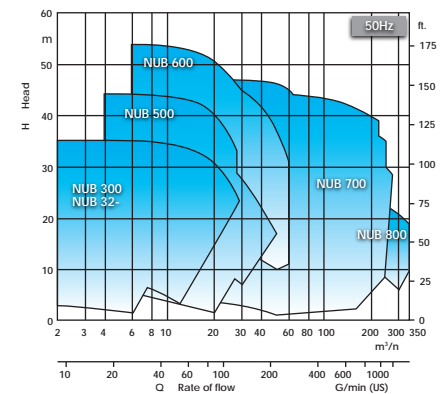

[Click here for complete Flow Curves](#)