

TOE-VA

Centrifugal Heat Transfer Pump

Shanley Pump
& Equipment, Inc.



TOE-MA

Features

Speck TOE-MA Magnetic Drive Centrifugal Pumps are designed for the transport and recirculation of organic heat transfer oils on mineral and/or synthetic basis as well as hot water heat transfer applications throughout the world. The TOE-MA Series are horizontal magnetic drive close-coupled pumps with end suction. The Direct-Coupled design eliminates the need to align pump and motor shafts.

Description

The Magnetic Coupling design also eliminates any temperature misalignment or seal leakage. Suction and Discharge mounting flanges for the TOE-MA Series are drilled to ANSI specifications and the casing is made from ductile cast iron. The TOE-MA performance data is impressive as well. 880 - 925 GPM, and 312ft. to 360ft. of Head with oil at temperatures of 625°F.

Suction and Discharge mounting flanges for the Speck TOE-MA Series are ANSI drilled. The robust design and construction of Speck Mag Drive pumps is due to a rigorous quality control system that begins at their manufacturing facilities where ISO:9001 requirements met throughout the entire manufacturing process resulting in a superior thermal heat transfer pump.









Shanley Pump & Equipment, Inc.
 2525 S. Clearbrook Drive
 Arlington Heights, IL 60005
P: 847.439.9200
F: 847.439.9388
 www.shanleypump.com
 sales@shanleypump.com

Usage

Speck TOE-MA Magnetic Drive Centrifugal Thermal Transfer Pumps are available to work in a variety of demanding industries where the movement of heated pumping media is required on a daily basis. Facilities with large baking and frying ovens, heated agitator and mixing tanks, flat glass production, solar power generation stations and ORC processes as well as the color and dye industry all have systems that would benefit from a Speck Thermal Centrifugal Pump.

Main Applications

-  Glass Industry
-  Steel Industry
-  Leather & Rubber Industry
-  Baking Industry
-  Heating Tank Mixing
-  Recirculation Pumps
-  Thermal Oil Pumping
-  Heat Transfer Pumps

GPM up to 880 GPM

PSI max. 232 PSI

TEMP hot oil up to 626 °F

HEAD 328 ft.

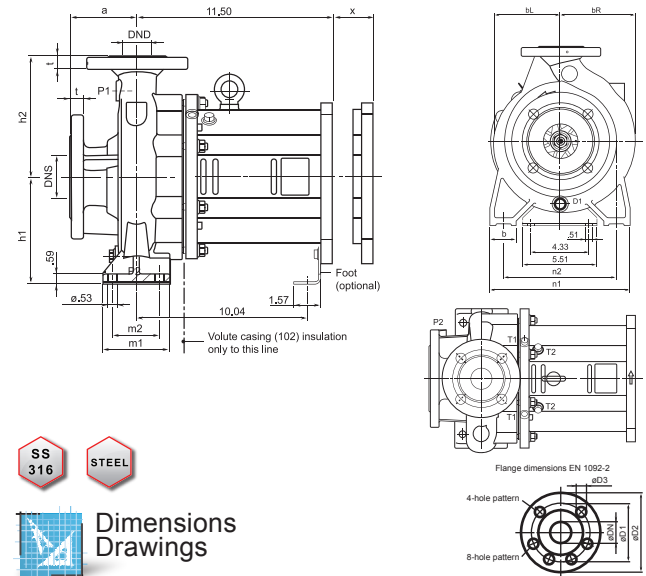

Dimensions Drawings

Please Click The Icon Above For More Information:



50HZ Performance Curve

